



Inter-Parliamentary Union

For democracy, for everyone.

**130**

years of empowering parliamentarians

# 141<sup>st</sup> IPU Assembly

Belgrade (Serbia)  
13-17 October 2019

**141<sup>st</sup>**  
**IPU**



Assembly

Belgrade (Serbia)  
13 - 17 October 2019

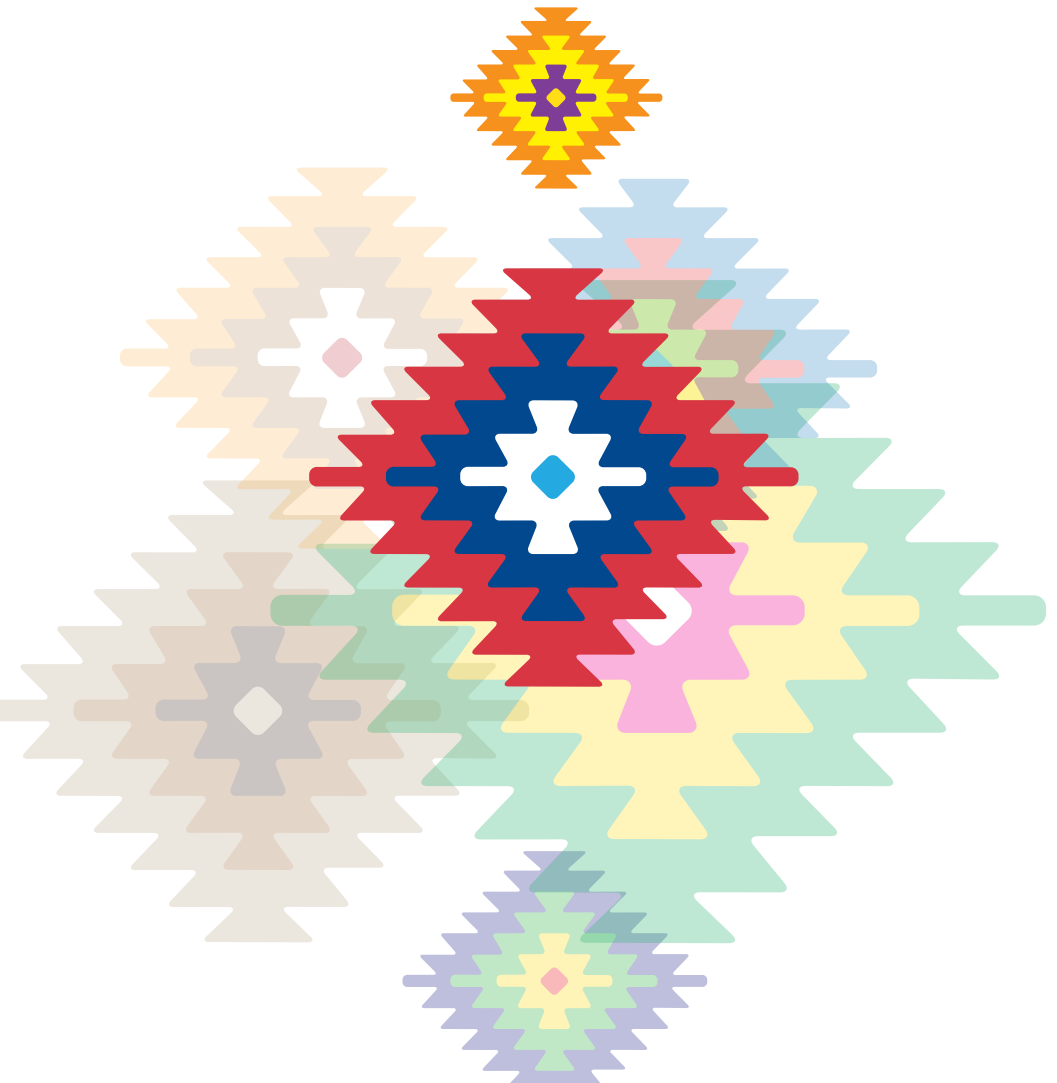

# **141<sup>st</sup> ASSEMBLY GUIDEBOOK**

**13–17 October 2019**

**Belgrade, Serbia**

# CONTENTS

OFFICIAL OPENING AND MEETING PLACES	3
OFFICIAL RECEPTIONS AND OTHER EVENTS	3
GENERAL TIMETABLE OF THE 141 <sup>ST</sup> ASSEMBLY AND RELATED MEETINGS	4
SEATING ARRANGEMENTS IN MEETING ROOMS	12
AGENDA OF THE ASSEMBLY	12
AGENDAS OF THE STANDING COMMITTEES	13
REGISTRATION OF SPEAKERS AND SPEAKING TIME FOR THE GENERAL DEBATE	15
ADDITIONAL INFORMATION	16
Registration and Information Desk	16
Table of votes at the Assembly	17
Assembly documents	18
Distribution of messages and non-official documentation	19
Results of the Assembly and related meetings	19
Summary records of the debates	19
Submission and control of documents	19
Distribution of documents	19
Simultaneous interpretation	20
Press service	20
Ensuring a safe and respectful Assembly	21
Informal and bilateral meeting rooms	21
Information and transport services	21
Typing pool, photocopying and print-on-demand service	23
Internet and Wi-Fi access	23
Assembly App	23
Medical service	23
Prayer room	23
No-smoking policy	23
Facilities	24
Delegation of the National Assembly of the Republic of Serbia to the 141 <sup>ST</sup> IPU Assembly:	25
STATUTORY BODIES	26
Assembly of the IPU	26
Governing Council of the IPU	26
Executive Committee	26
PRESIDENCY OF THE IPU AND ASSEMBLY SECRETARIAT	31
ASSOCIATION OF SECRETARIES GENERAL OF PARLIAMENTS (ASGP)	32
Governing bodies of the ASGP	33
EXCURSIONS	34
ASSEMBLY VENUES FLOOR PLANS	35
LIST OF OFFICIAL ASSEMBLY HOTELS	37
LIST OF EMBASSIES AND CONSULATES IN BELGRADE	39

## OFFICIAL OPENING AND MEETING PLACES

The Inaugural Ceremony of the 141<sup>st</sup> Assembly of the Inter-Parliamentary Union will take place on Sunday, 13 October, at 7.30 p.m. in the Blue Hall, Sava Centre, in the presence of H.E. Mr. Aleksandar Vučić, President of the Republic of Serbia.

**For admission to the Inaugural Ceremony and all other official events held during the Assembly, participants are kindly requested to wear their identity badges and present the appropriate invitation.**

The plenary sittings of the Assembly and its Standing Committees, as well as the meetings of the IPU Governing Council, the Executive Committee, the Forum of Women Parliamentarians, the Committee on the Human Rights of Parliamentarians, and the meetings of the Association of Secretaries General of Parliaments (ASGP) will also be held at the Sava Centre.

## OFFICIAL RECEPTIONS AND OTHER EVENTS

### Reception for the IPU Executive Committee

Host : H.E. Ms. Maja Gojkovic, Speaker of the National Assembly of Serbia  
Date and time : 11 October 2019, 7 p.m.  
Venue : Skadarlija, restaurant Dva Jelena, Belgrade

### Inaugural Ceremony and Reception

Host : H.E. Ms. Maja Gojkovic, Speaker of the National Assembly of Serbia  
Date and time : 13 October, 7.30 p.m.  
Venue : Blue Hall, Sava Centre

### Reception in Honour of Heads of Delegations (only)

Host : H.E. Ms. Maja Gojkovic, Speaker of the National Assembly of Serbia  
Date and time : 14 October 2019, 7 p.m.  
Venue : Central Hall, National Assembly, Belgrade

### Embassy Night

Date : 14 October 2019

### Reception in Honour of the Forum of Women Parliamentarians

Host : H.E. Ms. Maja Gojkovic, Speaker of the National Assembly of Serbia  
Date and time : 15 October 2019, 7 p.m.  
Venue : Beli dvor, Belgrade

## Cultural Evening

Host : H.E. Ms. Maja Gojkovic, Speaker of the National Assembly of Serbia  
Date and time : 16 October, 7 p.m.  
Venue : Kombank Hall, Belgrade

## Reception in Honour of Secretaries General

Host : Mr. Srdjan Smiljanic, Secretary General of the National Assembly of Serbia  
Date and time : 16 October 2019, 5 p.m.  
Venue : Central Hall, National Assembly, Belgrade

## GENERAL TIMETABLE OF THE 141<sup>st</sup> ASSEMBLY AND RELATED MEETINGS

*Belgrade, 13 to 17 October 2019*



### Thursday, 10 October 2019

	14.00 – 18.00	Beginning of Registration <i>Lobby, Building A, Sava Centre</i>
	14.30 – 18.00	Sub-Committee on Finance* <i>Art Café (ground floor), Building B, Sava Centre</i>

### Friday, 11 October 2019

	10.00 – 13.00	Executive Committee*
	15.00 – 18.00	<i>Art Café (ground floor), Building B, Sava Centre</i>

### Saturday, 12 October 2019

	09.00 – 10.00	Gender Partnership Group* <i>Art Café (ground floor), Building B, Sava Centre</i>
	09.30 – 13.00	Committee on the Human Rights of Parliamentarians* <i>Hall 3/1 (first floor), Building A, Sava Centre</i>
	10.00 – 13.00	Executive Committee* <i>Art Café (ground floor), Building B, Sava Centre</i>



14.30 – 18.00

Committee on the Human Rights of  
Parliamentarians\*  
*Hall 3/1 (first floor), Building A, Sava Centre*



15.00 – 18.00

Executive Committee\*  
*Art Café (ground floor), Building B, Sava  
Centre*

## Sunday, 13 October 2019



09.00 – 10.00

Bureau of Women Parliamentarians\*  
*Art Café (ground floor), Building B, Sava  
Centre*



09.30 – 10.30

Meeting of Advisers and Secretaries to  
delegations  
*Hall 2/0 (ground floor), Building A, Sava Centre*



10.30 – 13.00

**Forum of Women Parliamentarians**  
*Amphitheatre (ground floor), Building B, Sava  
Centre*



11.00 – 13.00

Meeting with the Chairpersons of the  
Geopolitical Groups and Presidents of the  
Standing Committees\*  
*Art Café (ground floor), Building B, Sava  
Centre*



11.00 – 13.00

Group of Facilitators for Cyprus\*  
*Hall 15/1 (first floor), Building A, Sava Centre*



11.30 – 13.00

Break out Group of the Forum of Women  
Parliamentarians  
*Hall 3/0 (ground floor), Building A, Sava Centre*



14.30 – 17.30

**Forum of Women Parliamentarians**  
*Amphitheatre (ground floor), Building B, Sava  
Centre*



14.30 – 18.00

Committee on the Human Rights of  
Parliamentarians\*  
*Hall 3/1 (first floor), Building A, Sava Centre*



15.00 – 18.30

High-Level Advisory Group on Countering  
Terrorism and Violent Extremism\*  
*Art Café (ground floor), Building B, Sava  
Centre*



19.30 – 20.30

**Inaugural Ceremony**  
*Blue Hall, Building B, Sava Centre*

# Monday, 14 October 2019



08.00 – 09.00

## Assembly Steering Committee\*

*Delegation Unit 10 (ground floor), Building A, Sava Centre*



09.00 – 10.00

## Board of the Forum of Young Parliamentarians\*

*Art Café (ground floor), Building B, Sava Centre*



09.00 – 11.00

## Governing Council

*Hall 1/0 (ground floor), Building A, Sava Centre*



09.00 – 13.00

## Standing Committee on Democracy and Human Rights

Debate on the draft resolution *Achieving universal health coverage by 2030: The role of parliaments in ensuring the right to health*  
*Amphitheatre (ground floor), Building B, Sava Centre*



09.00 – 13.00

## Standing Committee on Sustainable Development, Finance and Trade

- Debate on *Mainstreaming digitalization and the circular economy to achieve the SDGs, particularly responsible consumption and production*
- Segment on preparations for the *Parliamentary Meeting at the United Nations Climate Change Conference (COP 25) in Chile in December 2019*

*Hall 3/0 (ground floor), Building A, Sava Centre*

ASGP

11.00 – 12.30

## ASGP Meeting

*Hall 2/0 (ground floor), Building A, Sava Centre*



11.00 – 13.00

**Assembly:** Start of the General Debate on the theme *Strengthening international law: Parliamentary roles and mechanisms, and the contribution of regional cooperation*  
*Hall 1/0 (ground floor), Building A, Sava Centre*



11.00 – 13.00

Committee to Promote Respect for International Humanitarian Law\*

*Art Café (ground floor), Building B, Sava Centre*



13.00

**Group photo – all Heads of delegation**



14.30 – 17.00

**Assembly:** General Debate  
*Hall 1/0 (ground floor), Building A, Sava Centre*

**ASGP**

14.30 – 17.30

ASGP Meeting  
*Hall 2/0 (ground floor), Building A, Sava Centre*



14.30 – 18.00

Committee on the Human Rights of Parliamentarians\*  
*Hall 3/1 (first floor), Building A, Sava Centre*

**Standing Committee on Democracy and Human Rights**



14.30 – 18.30

Drafting in plenary of the draft resolution on *Achieving universal health coverage by 2030: The role of parliaments in ensuring the right to health*

*Amphitheatre (ground floor), Building B, Sava Centre*



14.30 – 18.30

**Forum of Young Parliamentarians of the IPU**

*Hall 3/0 (ground floor), Building A, Sava Centre*



17.00 – 18.30

**Assembly:**

- Decision on the emergency item  
*Hall 1/0 (ground floor), Building A, Sava Centre*

## Tuesday, 15 October 2019



09.00 – 10.30

Bureau of the Standing Committee on United Nations Affairs\*

*Art Café (ground floor), Building B, Sava Centre*



09.00 – 10.30

Bureau of the Standing Committee on Sustainable Development, Finance and Trade\*

*Hall 15/1 (first floor), Building A, Sava Centre*



	09.00 – 13.00 09.00 – 10.00 10.00 – 12.00 12.00 – 13.00	<b>Assembly</b> - Debate on the emergency item, - Continuation of the General Debate, and - Special segment to mark the 130 <sup>th</sup> Anniversary of the IPU <i>Hall 1/0 (ground floor), Building A, Sava Centre</i>
	09.00 – 13.00	<b>Standing Committee on Democracy and Human Rights</b> Completion of drafting in plenary of the draft resolution <i>Achieving universal health coverage by 2030: The role of parliaments in ensuring the right to health</i> <i>Amphitheatre (ground floor), Building B, Sava Centre</i>
	09.30 – 13.00	Committee on the Human Rights of Parliamentarians* <i>Hall 3/1 (first floor), Building A, Sava Centre</i>
<b>ASGP</b>	10.30 – 12.30	ASGP Meeting <i>Hall 2/0 (ground floor), Building A, Sava Centre</i>
	11.00 – 12.30	Bureau of the Standing Committee on Peace and International Security* <i>Art Café (ground floor), Building B, Sava Centre</i>
	11.00 – 12.30	Workshop on <i>Leaving no one behind in political representation: Gender and youth quotas</i> <i>Hall 3/0 (ground floor), Building A, Sava Centre</i>
	11.00 – 14.00	Advisory Group on Health* (English only) <i>Hall 15/1 (first floor), Building A, Sava Centre</i>
	14.30 – 16.00	Committee on Middle East Questions* <i>Hall 3/0 (ground floor), Building A, Sava Centre</i>
	14.30 - 17.30	Speakers' Dialogue* Roundtable and break-out sessions <i>Halls 3/1 and 15/1 (first floor), Building A, Sava Centre</i>
<b>ASGP</b>	14.30 – 17.30	ASGP Meeting <i>Hall 2/0 (ground floor), Building A, Sava Centre</i>



14.30 - 18.30

### Standing Committee on Peace and International Security

- Panel discussion on the implementation of the 2014 resolution entitled *Towards a nuclear-weapon-free world: The contribution of parliaments*
  - Panel discussion on the theme of *Criminalization of money laundering*
- Amphitheatre (ground floor), Building B, Sava Centre*



14.30 – 18.30

### Assembly

Continuation of the General Debate  
*Hall 1/0 (ground floor), Building A, Sava Centre*



14.30 – 18.30

Possible drafting committee on the emergency item\*

*Art Café (ground floor), Building B, Sava Centre*



16.30 – 18.30

Workshop on the *United Nations Convention on the Rights of the Child: 30 years on, achievements and challenges*  
*Hall 3/0 (ground floor), Building A, Sava Centre*

## Wednesday, 16 October 2019



09.00 – 10.00

Gender Partnership Group\*  
*Art Café (ground floor), Building B, Sava Centre*



09.00 – 10.30

Parity debate on the theme #Not In My Parliament: *National and regional strategies*  
*Amphitheatre (ground floor), Building B, Sava Centre*



09.00 – 11.00

Bureau of the Standing Committee on Democracy and Human Rights\*  
*Hall 3/1 (first floor), Building A, Sava Centre*



09.00 – 13.00

**Assembly:** Continuation of the General Debate  
*Hall 1/0 (ground floor), Building A, Sava Centre*



09.30 – 12.30

Workshop on SDG 8:  
*Achieving full and productive employment and decent work for all: The economic challenge of our time*  
*Hall 15/1 (first floor), Building A, Sava Centre*

	10.00 – 13.00	Executive Committee* <i>Art Café (ground floor), Building B, Sava Centre</i>
ASGP	10.30 – 12.30	ASGP Meeting <i>Hall 2/0 (ground floor), Building A, Sava Centre</i>
	11.00 – 13.00	<b>Standing Committee on Peace and International Security</b> Expert hearing <i>Parliamentary strategies to strengthen peace and security against threats and conflicts resulting from climate-related disasters and their consequences</i> <i>Amphitheatre (ground floor), Building B, Sava Centre</i>
	11.30 – 13.00	<b>Open session</b> of the Committee to Promote Respect for International Humanitarian Law: <i>Placing humanity first: The Geneva Conventions – Protecting people in armed conflict for 70 years</i> <i>Hall 3/1 (first floor), Building A, Sava Centre</i>
	14.30 – 16.30	<b>Standing Committee on Sustainable Development, Finance and Trade</b> Debate on follow-up to the resolution adopted in March 2014: <i>Towards risk-resilient development: Taking into consideration demographic trends and natural constraints</i> <i>Amphitheatre (ground floor), Building B, Sava Centre</i>
ASGP	14.30 – 17.30	ASGP Meeting <i>Hall 2/0 (ground floor), Building A, Sava Centre</i>
	14.30 – 17.30	Committee on Middle East Questions* <i>Art Café (ground floor), Building B, Sava Centre</i>
	14.30 – 18.00	Committee on the Human Rights of Parliamentarians* <i>Hall 3/1 (first floor), Building A, Sava Centre</i>
	14.30 – 18.30	<b>Assembly</b> - Adoption of the resolution on the emergency item, and - Special segment: Future Policy Award 2019 on Youth Empowerment - Conclusion of the General Debate <i>Hall 1/0 (ground floor), Building A, Sava Centre</i>



14.30 – 18.30

### Standing Committee on United Nations Affairs

- Panel discussion: *Respect for international law in keeping with the UN Charter and other relevant resolutions*
  - Panel discussion: *Survey on the relationship between parliaments and the United Nations*
- Hall 3/0 (ground floor), Building A, Sava Centre*



17.00 – 18.30

### Standing Committee on Democracy and Human Rights

Adoption of the draft resolution on *Achieving universal health coverage by 2030: The role of parliaments in ensuring the right to health*

*Amphitheatre (ground floor), Building B, Sava Centre*

## Thursday, 17 October 2019



08.30 – 10.30

Bureau of Women Parliamentarians\*  
*Art Café (ground floor), Building B, Sava Centre*



09.30 – 13.00

### Governing Council

- Decisions on the human rights of MPs, and
  - Reports of specialized meetings
- Hall 1/0 (ground floor), Building A, Sava Centre*
- Preliminary consultation on the 2021 Global Parliamentary Report
- Parliament in a changing world*



11.00 – 13.00

Jointly organized by the IPU and the ASGP  
*Hall 3/0 (ground floor), Building A, Sava Centre*



14.30 -

### Governing Council

*Hall 1/0 (ground floor), Building A, Sava Centre*



At the end of the Governing Council

### Assembly

- Adoption of resolutions
  - Reports of the Standing Committees
  - Outcome document of the General debate, and
  - Closing sitting
- Hall 1/0 (ground floor), Building A, Sava Centre*

Legend:

Assembly /  
Governing Council



Committees /  
Panel discussions



Other Assembly events,  
including *in camera*  
sessions



## SEATING ARRANGEMENTS IN MEETING ROOMS

As usual, lots have been drawn among the delegations participating in the session to determine which will be seated in the first row of the Plenary Hall.

The name of the delegation from **PERU** was drawn, and this delegation has accordingly been placed in the first row, on the left-hand side of the Chair. Other delegations follow in *English alphabetical order*.

Seats shall be allocated to each delegation in conformity with the Rules of the Assembly and of the Governing Council. On the basis of seats available at desks in the Plenary Hall, where possible, Members with delegations of up to five MPs will be allocated a total of four seats (two at desks), those with six to eight MPs six seats (three at desks) and those with nine or more MPs eight seats (four at desks).

Delegations are reminded that each Member of the IPU shall be represented on the Governing Council by three parliamentarians, provided that its representation includes both men and women. Each representative will then have one vote. A member who is unable to attend may be replaced by another representative, duly authorized for that purpose.

The first and last seats of each delegation are marked by a country nameplate.

For the Forum of Women Parliamentarians, Standing Committee plenary sessions and other meetings, delegates are invited to collect their country nameplate when entering the room and place it in front of them, clearly visible.

## AGENDA OF THE ASSEMBLY

1. Election of the President and Vice-Presidents of the 141<sup>st</sup> Assembly
2. Consideration of requests for the inclusion of an emergency item in the Assembly agenda
3. General Debate on the theme *Strengthening international law: Parliamentary roles and mechanisms, and the contribution of regional cooperation*
4. *Achieving universal health coverage by 2030: The role of parliaments in ensuring the right to health*  
(Standing Committee on Democracy and Human Rights)
5. Reports of the Standing Committees on Peace and International Security; Sustainable Development, Finance and Trade; and United Nations Affairs
6. Approval of the subject item for the Standing Committee on Democracy and Human Rights at the 143<sup>rd</sup> IPU Assembly and appointment of the Rapporteurs
7. Amendments to the IPU Statutes and Rules

## AGENDAS OF THE STANDING COMMITTEES

### Standing Committee on Peace and International Security

1. Adoption of the agenda
2. Approval of the summary record of the Committee's session held during the 140<sup>th</sup> IPU Assembly in Doha (April 2019)
3. Elections to the Bureau of the Standing Committee
4. Follow-up to the 2014 resolution *Towards a nuclear-weapon-free world: The contribution of parliaments*
5. Panel discussion on the theme of *Criminalization of money laundering*
6. Expert hearing on the theme *Parliamentary strategies to strengthen peace and security against threats and conflicts during climate-related disasters and their consequences*
7. Any other business

### Standing Committee on Sustainable Development, Finance and Trade

1. Adoption of the agenda
2. Approval of the summary record of the Committee's session held during the 140<sup>th</sup> IPU Assembly in Doha (April 2019)
3. Parliamentary contribution to the 2019 UN Climate Change Conference (COP 25)
4. Debate on the theme of *Mainstreaming digitalization and the circular economy to achieve the SDGs, particularly responsible consumption and production*
5. Follow-up to the IPU resolution *Towards risk-resilient development: Taking into consideration demographic trends and natural constraint*
6. Elections to the Bureau of the Standing Committee
7. Any other business

### Standing Committee on Democracy and Human Rights

1. Adoption of the agenda
2. Approval of the summary record of the Committee's session held during the 140<sup>th</sup> IPU Assembly in Doha (April 2019)
3. Preparation of the resolution entitled *Achieving Universal Health Coverage by 2030: The role of parliaments in ensuring the right to health*
4. Preparations for future Assemblies
5. Any other business

## Standing Committee on United Nations Affairs

1. Adoption of the agenda
2. Approval of the summary record of the Committee's session held during the 140<sup>th</sup> IPU Assembly in Doha (April 2019)
3. Panel discussion on *Respect for international law in keeping with the UN Charter and other relevant institutions*
4. Panel discussion on *The 2019 IPU survey on the relationship between parliaments and the United Nations*
5. Overview of major UN-related activities for 2020
6. Elections to the Bureau of the Standing Committee
7. Any other business

### **Other events**

- Workshop on leaving no one behind in political representation: *Gender and youth quotas*, 15 October, 11.00–12.30, Hall 3/0
- Special segment to mark the 130<sup>th</sup> Anniversary of the IPU, 15 October, 12.00–13.00, Hall 1/0
- Speakers' dialogue, 15 October, 14.30–17.30, Halls 3/1 and 15/1
- Workshop on the *United Nations Convention on the Rights of the Child: 30 years on, achievements and challenges*, 15 October, 16.30–18.30, Hall 3/0
- Workshop on SDG 8: *Achieving full and productive employment and decent work for all: The economic challenge of our time*, 16 October, 9.30–12.30, Hall 15/1
- Special segment: Future Policy Award 2019 on Youth Empowerment, 16 October, 15.00–16.15, Hall 1/0

## REGISTRATION OF SPEAKERS AND SPEAKING TIME FOR THE GENERAL DEBATE

Delegations may register at the Speakers' Registration Desk.

Venue	Registration Desk, outside the Plenary Hall (Hall 1/0, ground floor)
Opening hours	<ul style="list-style-type: none"> <li>• Sunday, 13 October from 11.00 to 17.00</li> <li>• Monday, 14 October from 9.00 to 13.00 and from 14.00 to 18.30</li> </ul>
Officer in charge	Mr. Ed Cooper
Number of speakers	<ul style="list-style-type: none"> <li>• IPU Members and Associate Members: up to three speakers <i>A third speaker will be registered if they are a young member of parliament (under 45 years of age)</i></li> <li>• Observers: only one speaker <i>According to the decision adopted at the 164<sup>th</sup> session of the Council in Brussels (April 1999). Each programme and organ of the United Nations will be allowed to register one speaker each.</i></li> </ul>
Speaking time	<ul style="list-style-type: none"> <li>• IPU Members and Associate Members: 7 to 9 minutes* per delegation, depending on its composition (unless the Assembly Steering Committee decides otherwise)</li> <li>• Observers: 3 minutes</li> </ul> <p>* <i>(depending on the number of persons registered to speak, the Assembly Steering Committee may decide to reduce speaking time)</i></p>
Segments in the list	<p>The Secretariat will register speakers to the following four segments:</p> <ul style="list-style-type: none"> <li>• Presiding officers</li> <li>• First speakers</li> <li>• Second speakers</li> <li>• Young parliamentarians</li> </ul>
Distribution of speeches	<p>Delegations are kindly invited to submit the texts of official speeches to <a href="mailto:speeches@ipu.org">speeches@ipu.org</a>. As far as possible, the texts of official statements delivered in the General Debate will be published on the Assembly webpage and will be part of the records of the Assembly. Due to technical limitations, only speeches in English, French and Spanish will be posted. Please note that the IPU Secretariat is not in a position to translate the texts of speeches.</p>



Final order of speakers	At 17.00 on Sunday, 13 October, the Secretariat will determine the final order of speakers for each segment by the public drawing of lots (at the speakers' registration desk).
Where to find the list?	The list of speakers will be available at the official documents tables located inside the Plenary Hall, at the Documents Distribution Service, as well as on the 141 <sup>st</sup> Assembly webpage and App.
Can we register after the drawing of lots?	Speakers registering after the drawing of lots will be added to the list (in their respective categories) in the order in which they have registered, until the Assembly closes the list of speakers. A revised list containing such additions will be issued at the end of each day.
How to change the order?	Delegates may exchange their place on the list with other speakers. In case of changes, please inform Ms. Anda Filip, Secretary of the Assembly. Any bilateral arrangements which may be made by delegations to exchange places in the list of speakers will not lead to a renumbering of the position held by speakers in the list.
Timekeeping	A green light will shine when the speaker commences; when the speaker has only one minute remaining, an orange light will shine; when the speaking time has been used up, a red light will flash. Second speakers from a delegation may find it useful to consult the timekeepers to ascertain the precise amount of time available to them for their statements.

## ADDITIONAL INFORMATION

### Registration and Information Desk

The Registration and Information Desk is located in the main lobby of the Sava Centre and will be open as follows:

- 14.00 to 18.00 on Thursday, 10 October;
- 8.00 to 18.30 from Friday, 11 to Wednesday, 16 October; and
- 8.00 to 18.00 on Thursday, 17 October.

All participants are requested to register with the Registration Desk, which will distribute the identity badges. Delegates may also collect documents and other communications from their pigeonholes, as well as book meeting rooms with this service.

The provisional list of delegates will be available for consultation on the IPU website and App. A hard copy can be obtained, upon request, from the Documents Distribution Service. In the afternoon of Monday, 14 October, delegation coordinators and secretaries are kindly requested to collect from the Registration Desk a document containing information

relating to their delegation. Any modifications should be signed by the Head of the delegation and given to Ms. M. Filippin at the Registration Desk not later than 16 October at 12 noon.

As part of the IPU's paper smart policy, the list of participants is no longer a bilingual document. The information in the list will appear in the language of registration and will include a glossary of terms.

The colour of the identity badges corresponds to the following categories of participants:

### **Colour**

Members of Parliament	Dark blue
Secretaries, Advisers of delegations	Green
Observers	Yellow
ASGP	Red
Members of the Serbian Parliament	Burgundy
Diplomatic Corps	Light blue
Special Guests	Black
Accompanying Persons	Light pink
Assembly Secretariat	Pink
Host Secretariat	Grey
Protocol	Light brown
Media	Orange
Public	White
Security	Dark brown
Service Providers	Beige

For security reasons, admission to the Assembly facilities and to all programme activities will be limited to persons wearing identity badges received at the time of registration. All participants are therefore requested to wear their identity badges at all times.

### **Table of votes at the Assembly**

In conformity with Rule 29 of the Assembly Rules, the table indicating the number of votes to which delegations taking part in the session are entitled will be distributed at the opening of the Assembly. Delegates are reminded that votes are allocated in accordance with the provisions of Article 15 of the Statutes, which stipulates as follows:

#### **ARTICLE 15**

1. Only delegates present in person shall have the right to vote.
2. The number of votes to which each Member of the IPU is entitled shall be calculated on the following basis:
  - (a) Each Member of the IPU shall have a minimum of ten votes;

- (b) Each Member of the IPU shall have the following additional number of votes in relation to the population of its country:

From	1	to	5	million inhabitants:	1 vote
From over	5	to	10	“	2 votes
“ “ “	10	to	20	“	3
“ “ “	20	to	30	“	4
“ “ “	30	to	40	“	5
“ “ “	40	to	50	“	6
“ “ “	50	to	60	“	7
“ “ “	60	to	80	“	8
“ “ “	80	to	100	“	9
“ “ “	100	to	150	“	10
“ “ “	150	to	200	“	11
“ “ “	200	to	300	“	12
From over	“		300	“	13

- (c) Any delegation composed exclusively of parliamentarians of the same sex shall have a minimum of eight votes (instead of the 10 for mixed delegations) at the Assembly of the Inter-Parliamentary Union. For delegations entitled to a certain number of additional votes, the overall calculation will be made on the basis of eight votes instead of 10.
3. A delegation may split its votes so as to express the diverse views of its members. No one delegate may record more than 10 votes.

## Assembly documents

The Secretary General has overall responsibility for authorizing the circulation of all official documents for the session.

Before the opening of each session, all meeting documents are on the tables inside the meeting rooms. In keeping with the decision by the IPU governing bodies to reduce the

carbon footprint of the Organization and continue to diminish paper waste, only a limited number of documentation sets will be printed for the various sessions of the Assembly.

Delegates who wish to obtain additional copies of documents posted on the IPU website may use the print-on-demand service available at the Typing Pool and Photocopying Service for delegates (close to Hall 2/0). All documents on the IPU website are also posted on the Assembly App.

The Assembly Journal providing the latest updates on the programme of meetings and other information is available in meeting rooms and at the Information Counter, as well as on the IPU website ([www.ipu.org/event/141st-assembly-and-related-meetings](http://www.ipu.org/event/141st-assembly-and-related-meetings)) and Assembly App.

## **Distribution of messages and non-official documentation**

The transmission of messages through the Registration and Information Desk is a service made available to delegations with a view to facilitating communications on matters relating to the Assembly and its proceedings.

Delegations that wish to share information on any question other than those related to the working of the sessions may do so, under their own responsibility, by leaving documentation on tables set aside for this purpose, close to the Plenary Hall (Hall 1/0) area.

## **Results of the Assembly and related meetings**

All delegations will receive one printed copy of the Results of the 141<sup>st</sup> Assembly. Members of the IPU are also reminded that the different sections of the brochure are accessible from the IPU website ([www.ipu.org](http://www.ipu.org)) and can be downloaded in PDF format two weeks after the Assembly.

## **Summary records of the debates**

The Summary Records of the Governing Council, of the Assembly, and of the four Standing Committees, will be prepared by the Secretariat and posted on the website within three months after the Assembly.

## **Submission and control of documents**

Delegations wishing to submit documents relating to the agenda of the Assembly and of the Governing Council or transmit any information to the Secretariat of the Assembly (change in their Executive Bureau, contact details, etc.) are requested to do so at this Service, located in Hall 6/1, on the first floor. The person in charge of this service is Ms. C. Bon.

## **Distribution of documents**

As usual, working documents will be available to delegates in the various meeting rooms. Additional copies can be obtained from the Documents Distribution Service, located outside the main entrance of the Plenary Hall (Hall 1/0). The person in charge of this service is Mr. A.R. Farzaam.

## Simultaneous interpretation

The IPU Secretariat will provide simultaneous interpretation in English, French, Arabic and Spanish at the meetings of all statutory bodies.

Five other interpretation channels have been reserved for Chinese, Japanese, Portuguese, Russian and Serbian at sittings of the Assembly and the Governing Council, and for some sessions of the Standing Committees. These booths are provided free of charge and may be used by the interpretation teams of these languages. The number of additional booths available in the Plenary Hall is limited. The related costs incurred must be borne by the requesting party. All such requests are handled on a first-come, first-served basis.

Delegates may use another language provided that they arrange for their speech to be interpreted into one of the IPU's official languages (English and French) by a person designated by them, who will be given access to an interpretation booth. To allow for all necessary arrangements to be made in good time, delegations should contact well in advance the Chief Interpreter (Ms. F. Steinig-Huang) or the English booth interpreters assigned to the meeting at which the speech will be delivered. Moreover, eight copies of the translation of the speech into one of the IPU's official languages should be given to the Chief Interpreter or to the English booth for distribution to the other interpreters.

Official statements delivered in the General Debate are published on the Assembly webpage and form part of the official records of the Assembly. All delegations are therefore encouraged to send their statements to [speeches@ipu.org](mailto:speeches@ipu.org). Due to technical limitations, only speeches in English, French and Spanish will be posted.

E-mailing the speech (**a minimum of three hours before it is to be made**) will also help to ensure a high quality of simultaneous interpretation into the other working languages.

## Press service

A press service (Delegation Unit 7, ground floor) will operate throughout the Assembly to answer media enquiries and help facilitate press interviews. The person in charge of this service is Mr. T. Fitzsimons, Communications Director, who can be contacted by email at [tf@ipu.org](mailto:tf@ipu.org) or telephone: +41 79 854 31 53. Mr. Fitzsimons will also assist delegations wishing to meet with the press.

Journalists wishing to cover the Assembly must receive accreditation from the Press Service in order to obtain the necessary documentation and identity badges.

The Press Centre is located on the second floor and is equipped with computers, the Internet and monitors to follow the Assembly proceedings. The Press Centre contains a press conference room.

The IPU President, the Speaker of the National Assembly of the Republic of Serbia and the IPU Secretary General will hold two press conferences on 13 and 17 October at 13.00, at the Press Centre, second floor, Building A, Sava Centre.

## Social media



Get the latest information on the 141<sup>st</sup> IPU Assembly's programme and events by following us on Twitter ([www.twitter.com/ipuparliament](http://www.twitter.com/ipuparliament)). The Assembly's official hashtag is #IPU141.



Photos from the 141<sup>st</sup> Assembly of the IPU will be posted on Flickr ([www.ipu.org/141pics](http://www.ipu.org/141pics)). For information on the official photo bank, please visit the Press Service.



Instagram: [www.instagram.com/ipu.parliament\\_official](http://www.instagram.com/ipu.parliament_official)



Facebook: [www.facebook.com/InterParliamentaryUnion](http://www.facebook.com/InterParliamentaryUnion)



YouTube: [www.youtube.com/user/iparliamentaryunion](http://www.youtube.com/user/iparliamentaryunion)

## Ensuring a safe and respectful Assembly

The IPU is committed to protecting and promoting the freedom of opinion and expression in its meetings; however, abusive language, expressions of intolerance and incitement to discrimination, hostility or violence are unacceptable. Speakers shall refrain from such conduct. The presiding officer of the meeting may take any action deemed necessary to call to order anyone who disrupts the proceedings in this way.

The IPU is also committed to ensuring a working environment for the Assembly that is free of sexism and sexual harassment. All those working for or on behalf of the IPU, delegates and other attendees are expected to conduct themselves in a professional and respectful manner, and to actively prevent sexism, sexual harassment and misconduct.

## Informal and bilateral meeting rooms

On the Assembly premises, there are two meeting rooms available for geopolitical and other group meetings, as well as some bilateral meeting rooms. Reservations for the informal meeting rooms are handled by the IPU Information Desk (Sava Centre lobby). Any delegation wishing to reserve a bilateral meeting room may contact Ms. S.-A. Sader by e-mail: [sas@ipu.org](mailto:sas@ipu.org) or through the Submission and Control of Documents Service (Hall 6/1). All reservations are made on a first-come, first-served basis.

## Information and transport services

The National Assembly will welcome all participants of the upcoming 141<sup>st</sup> IPU Assembly. To this end, please provide, as soon as possible, details about the arrival and departure of the members of your delegations.

At Nikola Tesla Belgrade Airport, volunteers who will be wearing T-shirts with a 141<sup>st</sup> IPU logo will welcome all participants of the 141<sup>st</sup> IPU Assembly.

A special passport control line will be provided, marked "141<sup>st</sup> IPU".

The baggage will arrive at a separate baggage carousel marked "141<sup>st</sup> IPU".

At Nikola Tesla Belgrade Airport, in the baggage claim sector, before the customs control, there will be an information desk set up for all participants of the 141<sup>st</sup> IPU Assembly.

Please, label your baggage with the stickers provided for you in the invitation package.

A shuttle service will be provided to selected hotels for all members of delegations.

Liaison officers, assigned to national delegations, will be waiting for you on the bus, which will be outside the airport exit, after the customs control.

Speakers of national parliaments, as VIP guests, will be greeted at the VIP lounge of Nikola Tesla Belgrade Airport.

A 1+3 format for the Speaker and their entourage is envisaged at the VIP lounge.

Speakers of national parliaments will have at their disposal a special passenger vehicle, an accompanying liaison officer and a representative of the Ministry of Interior of the Republic of Serbia.

Other security measures will be determined by the Ministry of Interior of the Republic of Serbia.

Speakers of national parliaments traveling to Serbia by car (by land) will have a police escort to Belgrade or to the hotel where they are accommodated.

Should the secretaries of the delegations or the representatives of embassies, in the formats of which the Speaker of Parliament is included, have any further questions, please contact us by notes or by e-mail, at the following addresses: [maja.draskovic@parlament.rs](mailto:maja.draskovic@parlament.rs) and [dragan.petrovic@mfa.rs](mailto:dragan.petrovic@mfa.rs).

The National Assembly will organize transport on departure for all participants of the 141<sup>st</sup> IPU Assembly from their hotel to Nikola Tesla Belgrade Airport. We would therefore appreciate it if you could send any changes to your plans in a timely manner to the 141<sup>st</sup> IPU address of the National Assembly of the Republic of Serbia: [ipu@parlament.rs](mailto:ipu@parlament.rs) and [jasminka.urosevic@parlament.rs](mailto:jasminka.urosevic@parlament.rs)

The shuttle buses will be in service from 10 to 17 October 2019.

The shuttle timetable is available online on the 141<sup>st</sup> IPU Assembly website in the transport service section.

## Typing pool, photocopying and print-on-demand service

The typing pool, photocopying and print-on-demand service for delegates (ground floor, close to Hall 2/0, Building A) is open from 10 to 17 October. Delegates may request additional copies of all documents posted on the IPU website.

## Internet and Wi-Fi access

Free Internet access for delegates will be available from 10 to 17 October, from 8.30 a.m. to 6.30 p.m.; this service is close to the Registration and Information Desk. Wi-Fi access is also available throughout the building, using the following codes: user name **"141IPUSerbia"** and password **"IPUAssembly"**.

## Assembly App

The App is available from the App store on iOS devices and Play Store on Android. Search for "Crowdcompass attendeehub". Once downloaded, open the AttendeeHub app and enter the corresponding Assembly session number, i.e. IPU 141 Assembly. Alternatively, the IPU Secretariat will be pleased to send delegates an invitation by e-mail ([sas@ipu.org](mailto:sas@ipu.org)).

The purpose of the App is to facilitate the online consultation of official IPU documents and to enhance delegates' participation in IPU Assemblies. The hard-coded text of the App is available in English, French, German, Portuguese and Spanish. A user manual in English and French is available on the Assembly webpage.

As part of the IPU's ongoing paper smart policy, the feature under the icon "delegates' services" allows delegations to post information, usually contained in printed brochures, on the composition of their delegation to the IPU Assembly. Any delegation that wishes to take advantage of this new service should forward the file in pdf format (not more than 10MB) to [sas@ipu.org](mailto:sas@ipu.org).

## Medical service

A first-aid medical service will be available on the Assembly premises.

The room is opposite the plenary Hall 1 (ground floor), Building A.

There will also be an ambulance on stand-by at the Assembly venue, as well as at all official hotels and social events.

## Prayer room

Delegates are informed that there is a prayer room on the premises of the convention centre. The prayer room is next to the Delegation Unit 15/1, first floor, Building A.

## No-smoking policy

There is a no-smoking policy in effect in all meeting rooms. Delegates wishing to smoke are invited to use the areas designated for this purpose.



## Facilities

Assembly participants will have access to the following services at the Assembly venue:

### **Restaurants, cafeteria and bars**

Building A

**Restaurant:** Buffet style, all you can eat. Open daily 12.00–19.00.

**Bar 1:** Variety of drinks, snacks and sandwiches. Open daily 8.00–20.00.

**Bar 2:** Bar on the second level – media centre: only coffee and soft drinks. Open daily 8.00–20.00.

**Small shop “Kiosk”:** News-stand and shop offering a variety of soft drinks and snacks. Open daily 8.00–20.00.

### **Banks**

There are two ATM machines in the main lobby of the Sava Centre.

### **Postal services**

Full service post office. Open daily 8.00–20.00.

### **Rent a car**

There are four car rental agencies on the ground floor: Skill, Central, City car and Euro Star.

### **Travel agency**

The tourist organization of Serbia and the tourist organization of Belgrade will be present in the Sava Centre, building A, behind Hall 1 and Hall 2, presenting tourist destinations and offering a variety of excursions in and outside Belgrade, including special sightseeing tours, museums and other points of interest. Open daily 9.00–19.00.

### **Souvenir shop**

There is a big souvenir shop on the ground floor at the media entrance. Open daily 9.00–19.00.

### **Transport desk**

At the information centre in the main lobby.

### **Hairdressing salon**

There are two hairdressing salons on the ground floor, open 9.00–20.00.

### **Shops and boutiques**

There is a selection of shops and boutiques on the ground floor. Open daily 10.00–20.00.

All the services are located on the ground floor, Building A, Sava Centre.

## Delegation of the National Assembly of the Republic of Serbia to the 141<sup>st</sup> IPU Assembly:

- Mr. Vladimir Orlić, Head of Delegation
- Ms. Sandra Božić, Member of the Delegation
- Mr. Žarko Obradović, Member of the Delegation
- Mr. Vladimir Marinković, Deputy Speaker of the National Assembly of the Republic of Serbia, Member of the Delegation
- Ms. Gordana Čomić, Deputy Speaker of the National Assembly of the Republic of Serbia, Member of the Delegation
- Mr. Milorad Mijatović, Member of the Delegation
- Ms. Aleksandra Jerkov, Member of the Delegation
- Ms. Sanda Rašković Ivić, Member of the Delegation
- Ms. Mira Petrović, Member of the Delegation
- Mr. Mladen Grujić, Member of the Delegation
- Ms. Jelena Mijatović, Member of the Delegation
- Ms. Snežana Bogosavljević Bošković, Member of the Delegation

# STATUTORY BODIES

## Assembly of the IPU

### President

The Assembly will elect its President at the opening of its proceedings on Monday, 14 October at 11.00.

### Steering Committee

Under Assembly Rule 9, the Steering Committee is composed of the President of the Assembly, the President of the IPU and the Vice-President of the IPU Executive Committee. The Presidents of the Standing Committees may take part in an advisory capacity in the work of the Steering Committee, which is assisted by the IPU Secretary General.

### Standing Committee – Peace and International Security

President:	Mr. J.I. Echániz (Spain)
Vice-President:	Mr. S. Rakhmanov (Belarus)
Secretary:	Ms. Laurence Marzal

### Standing Committee – Sustainable Development, Finance and Trade

President:	Ms. V. Muzenda Tsitsi (Zimbabwe)
Vice-President:	Ms. W. Bani Mustafa (Jordan)
Secretary:	Ms. Aleksandra Blagojevic

### Standing Committee – Democracy and Human Rights

President:	Mr. A.Y. Desai (India)
Vice-President:	Ms. A. Gerken (Netherlands)
Secretary:	Mr. Andy Richardson

### Standing Committee – United Nations Affairs

President:	Mr. J.C. Romero (Argentina)
Vice-President:	Ms. S. Al-Hashem (Kuwait)
Secretary:	Ms. Paddy Torsney

## Governing Council of the IPU

President:	Ms. G. Cuevas Barron (Mexico)
------------	-------------------------------

## Executive Committee

President:	Ms. G. Cuevas Barron (Mexico)
Vice-President:	Mr. K. Kosachev (Russian Federation)

IPU Vice-Presidents:	Mr. A. Lins (Brazil)
	Mr. A. Abdel Aal (Egypt)
	Mr. D. McGuinty (Canada)
	Mr. Nguyen Van Giau (Viet Nam)

Members:	Mr. K. Jalali (Islamic Republic of Iran) Ms. M.I. Oliveira Valente (Angola) Mr. K.M. Lusaka (Kenya) Ms. H. Haukeland Liadal (Norway) Ms. Y. Ferrer Gómez (Cuba) Ms. M. Kiener Nellen (Switzerland) Mr. G. Chen (China) Mr. G. Gali Ngothé (Chad) Mr. M. Grujic (Serbia) Ms. A.D. Mergane Kanouté (Senegal)
Ex officio:	Ms. A. Albasti (United Arab Emirates) First Vice-President of the Bureau of Women MPs Mr. M. Bouva (Suriname) President of the Board of the Forum of Young MPs

## **Secretariat of the IPU**

### Secretary General

Mr. Martin Chungong

### Executive Office

Mr. Mokhtar Omar, Senior Adviser to the Secretary General  
Ms. Sharon Varturk, Executive Assistant  
Ms. Clarita Montant, Consultant

### Division for Member Parliaments and External Relations

Ms. Anda Filip, Director  
Ms. Sally-Anne Sader, Conference Services Officer  
Mr. Roberto Rodriguez Valencia, External Relations Officer

#### *Language Services*

Mr. Hervé Compagnion, Senior French Reviser  
Ms. Sarah Waller, Senior English Reviser

#### *Documents Control Service*

Ms. Catherine Bon, Team Leader

### Office of the Permanent Observer of the IPU to the United Nations

Ms. Paddy Torsney, Head  
Mr. Alessandro Motter, Senior Adviser

### Division of Programmes

Ms. Kareen Jabre, Director

#### *Technical Cooperation*

Ms. Norah Babic, Programme Manager  
Ms. Laurence Marzal, Programme Officer  
Mr. Jonathan Lang, Project Officer

#### *International Development*

Ms. Aleksandra Blagojevic, Programme Manager  
Ms. Isabel Obadiaru, Consultant  
Ms. Miriam Sangiorgio, Consultant

#### *Parliamentary Standards Setting and Knowledge Generation*

Mr. Andy Richardson, Programme Manager  
Ms. Hiroko Yamaguchi, Research and Database Officer  
Ms. Kee Young Seo, Research Officer  
Ms. Irena Mijanovic, Consultant

#### *Gender Partnership Programme*

Ms. Zeina Hilal, Programme Manager  
Ms. Mariana Duarte Mützenber, Programme Officer  
Ms. Brigitte Filion, Consultant

#### *Youth Participation*

Ms. Zeina Hilal, Programme Manager  
Mr. Jonathan Lang, Project Officer

#### Human Rights Programme

Mr. Rogier Huizenga, Programme Manager  
Mr. Akiyo Afouda, Programme Officer  
Ms. Boutayna Lamharzi, Consultant

#### Communications Division

Mr. Thomas Fitzsimons, Director  
Ms. Suroor Alikhan, Web and Social Media Editor  
Mr. Pieyre-Bernard Castelier, Information Systems Officer

#### Division of Support Services

Ms. Andrée Lorber-Willis, Director  
Mr. Ed Cooper, Senior Finance Officer

#### *Documents reproduction service*

Mr. Roshid Farzaam, Document Management Assistant

### **Assembly responsibilities**

#### Assembly

Ms. Anda Filip, Secretary  
Ms. Andrée Lorber-Willis  
Mr. Ed Cooper  
Mr. Roberto Rodriguez Valencia

Governing Council

Mr. Akiyo Afouda  
Ms. Sharon Varturk

Executive Committee

Mr. Akiyo Afouda  
Ms. Sharon Varturk

Sub-Committee on Finance

Ms. Andrée Lorber-Willis, Secretary  
Mr. Ed Cooper

Gender Partnership Group

Ms. Kareen Jabre, Secretary  
Ms. Zeina Hilal  
Ms. Mariana Duarte Mützenberg

Forum and Bureau of Women Parliamentarians

Ms. Zeina Hilal, Secretary  
Ms. Mariana Duarte Mützenberg  
Ms. Brigitte Filion

Forum of Young Parliamentarians

Ms. Zeina Hilal, Secretary  
Mr. Jonathan Lang  
Mr. Roberto Rodriguez Valencia

Committee on the Human Rights of Parliamentarians

Mr. Rogier Huizenga, Secretary  
Ms. Boutayna Lamharzi

Committee on Middle East Questions

Mr. Martin Chungong, Secretary  
Mr. Mokhtar Omar

Standing Committee – Peace and International Security

Ms. Laurence Marzal, Secretary  
Mr. Jonathan Lang

Standing Committee – Sustainable Development, Finance and Trade

Ms. Aleksandra Blagojevic, Secretary  
Ms. Isabel Obadiaru

Standing Committee – Democracy and Human Rights

Mr. Andy Richardson, Secretary  
Ms. Mariana Duarte Mützenberg

Standing Committee – United Nations Affairs

Ms. Paddy Torsney, Secretary  
Mr. Alessandro Motter

Drafting Committee on the Emergency Item  
Ms. Norah Babic, Joint Secretary  
Ms. Hiroko Yamaguchi, Joint Secretary

Committee to Promote and Respect International Humanitarian Law  
Ms. Kareen Jabre, Secretary

Media and Press  
Mr. Thomas Fitzsimons, Director  
Ms. Suroor Alikhan

Conference Services  
Ms. Sally-Anne Sader

Submission and Control of Documents  
Ms. Catherine Bon

Language Services  
Mr. Hervé Compagnion, Senior French Reviser  
Ms. Sarah Waller, Senior English Reviser  
Ms. Frances Steinig-Huang, Chief Interpreter, Head: English, French and Spanish teams  
Mr. Chawki Rayess, Chief Interpreter, Head of the Arabic team

IT Support  
Mr. Pieyre-Bernard Castelier

Document Reproduction and Distribution Service  
Mr. Roshid Farzaam

Registration and Information Desk  
Ms. Marina Filippin

## PRESIDENCY OF THE IPU AND ASSEMBLY SECRETARIAT

	LOCATION	TELEPHONE
President of the Inter-Parliamentary Union Ms. Gabriela Cuevas Barron	Delegation Unit 9	+381(0)11 2206800
President's Secretariat: Ms. Nathalie Michaud-Chiovetta	Delegation Unit 9	+381(0)11 2206801
Secretary General of the Inter-Parliamentary Union Mr. Martin Chungong	Delegation Unit 8	+381(0)11 2206802
Executive Office Senior Adviser, Mr. Mokhtar Omar Executive Assistant, Ms. Sharon Varturk	Delegation Unit 8	+381(0)11 2206803
Directors' Office Ms. Anda Filip, Members and External Relations Ms. Andrée Lorber-Willis, Support Services Ms. Kareen Jabre, Programmes Mr. Thomas Fitzsimons, Communications	Delegation Unit 7	+381(0)11 2206806
Communications Mr. Thomas Fitzsimons, Director Ms. Suroor Alikhan, Web and Social Media	Delegation Unit 7	+381(0)11 2206807
French Translation Mr. Hervé Compagnion	IPU Secretariat Hall 6/1	+381(0)11 2206808
English Editing and Translation Ms. Sarah Waller	IPU Secretariat Hall 6/1	+381(0)11 2206809
Documents Control service Team Leader, Ms. Catherine Bon	IPU Secretariat Hall 6/1	+381(0)11 2206810
Distribution of Documents Officer-in-charge, Mr. Roshid Farzaam	Hall 3/0 Foyer	+381(0)11 2206811
Registration and Information Desk Ms. Marina Filippin	Sava Centre lobby	+381(0)11 2206812
Typing pool, Photocopying and Print-on-demand Service for delegates	Close to Hall 2/0	+381(0)11 2206813
President of the ASGP Mr. Philippe Schwab	Japanese Lounge (first floor)	+381(0)11 2206814
Joint Secretaries of the ASGP Ms. Rhiannon Hollis Ms. Perrine Preuvot	Japanese Lounge (first floor)	381(0)11 2206815



# ASSOCIATION OF SECRETARIES GENERAL OF PARLIAMENTS (ASGP)

## Timetable

### Sunday, 13 October 2019

- 9.00 Excursion (SC, B entrance)  
Monastery Krusedol, Sremski Karlovci (with peace chapel), visit to winery with tasting and snack, Novi Sad (panoramic sightseeing), return to BG

### Monday, 14 October 2019

- 9.30 Executive Committee  
Japanese Lounge (first floor)
- 11.00 Plenary sitting  
Hall 2/0
- 14.30 Plenary sitting  
Hall 2/0

### Tuesday, 15 October 2019

- 9.30 Executive Committee  
Japanese Lounge (first floor)
- 10.30 Plenary sitting  
Hall 2/0
- 14.30 Plenary sitting  
Hall 2/0

### Wednesday, 16 October 2019

- 9.30 Executive Committee  
Japanese Lounge (first floor)
- 10.30 Plenary sitting  
Hall 2/0
- 14.30 Plenary sitting  
Hall 2/0
- 18.00 Visit to the National Assembly of the Republic of Serbia

## Governing bodies of the ASGP

### Executive Committee

President: Mr. Philippe Schwab (Switzerland)

Vice-Presidents: Mr. José Manuel Araújo (Portugal)  
Mr. Najib El Khadi (Morocco)

Members: Mr. Allam Ali Jaafar Al-Kandari (Kuwait)  
Ms. Lydia Kandetu (Namibia)  
Ms. Jane Lubowe Kibirige (Uganda)  
Mr. Givi Mikanadze (Georgia)  
Mr. José Pedro Montero (Uruguay)  
Mr. Christophe Pallez (France)  
Mr. Charles Robert (Canada)  
Mr. Desh Deepak Verma (India)

### Secretariat

Ms. Rhiannon Hollis (United Kingdom)  
Ms. Perrine Preuvot (France)

## Additional Information

### EXCURSIONS

#### Excursions outside Belgrade

All participants have a choice of two complementary excursions outside Belgrade for the following days:

##### 12 October 2019

- Smederevo, Viminacium and Golubac, 10.00–17.30
- Monasteries of Fruska Gora, 10.00–16.45

##### 13 October 2019

- Topola and Oplenac, 10.00–15.45
- Novi Sad and Sremski Karlovci, 10.00–17.30

##### 18 October 2019

- Smederevo, Viminacium and Golubac, 10.00–17.30
- Novi Sad and Sremski Karlovci, 10.00–17.30

**Please complete the form and send it to [office@serbiaexcursions.com](mailto:office@serbiaexcursions.com) no later than 1 October 2019.**

For any additional questions, please call: +381 11 328 1918.

#### Excursions in Belgrade

##### ***Bus tours***

A complementary Belgrade sightseeing tour will be organized once per day, from 13 October to 18 October. **Departure in front of the Sava Centre, at 13.00, duration approximately two hours.**

##### ***Boat tours***

A complementary cruise on the Danube and Sava Rivers will be organized once per day, from 13 October to 17 October. **Departure in front of the Sava Centre at 13.00, duration approximately two hours.**

During the 141<sup>st</sup> IPU Assembly, the tourist organization of Serbia (<http://www.serbia.travel/home.779.html>) and the tourist organization of Belgrade ([www.tob.rs/en](http://www.tob.rs/en)) will be on-site in the Sava Centre and offering an imposing array of excursions in and outside of Belgrade at preferential rates.

# ASSEMBLY VENUES FLOOR PLANS

## Ground floor

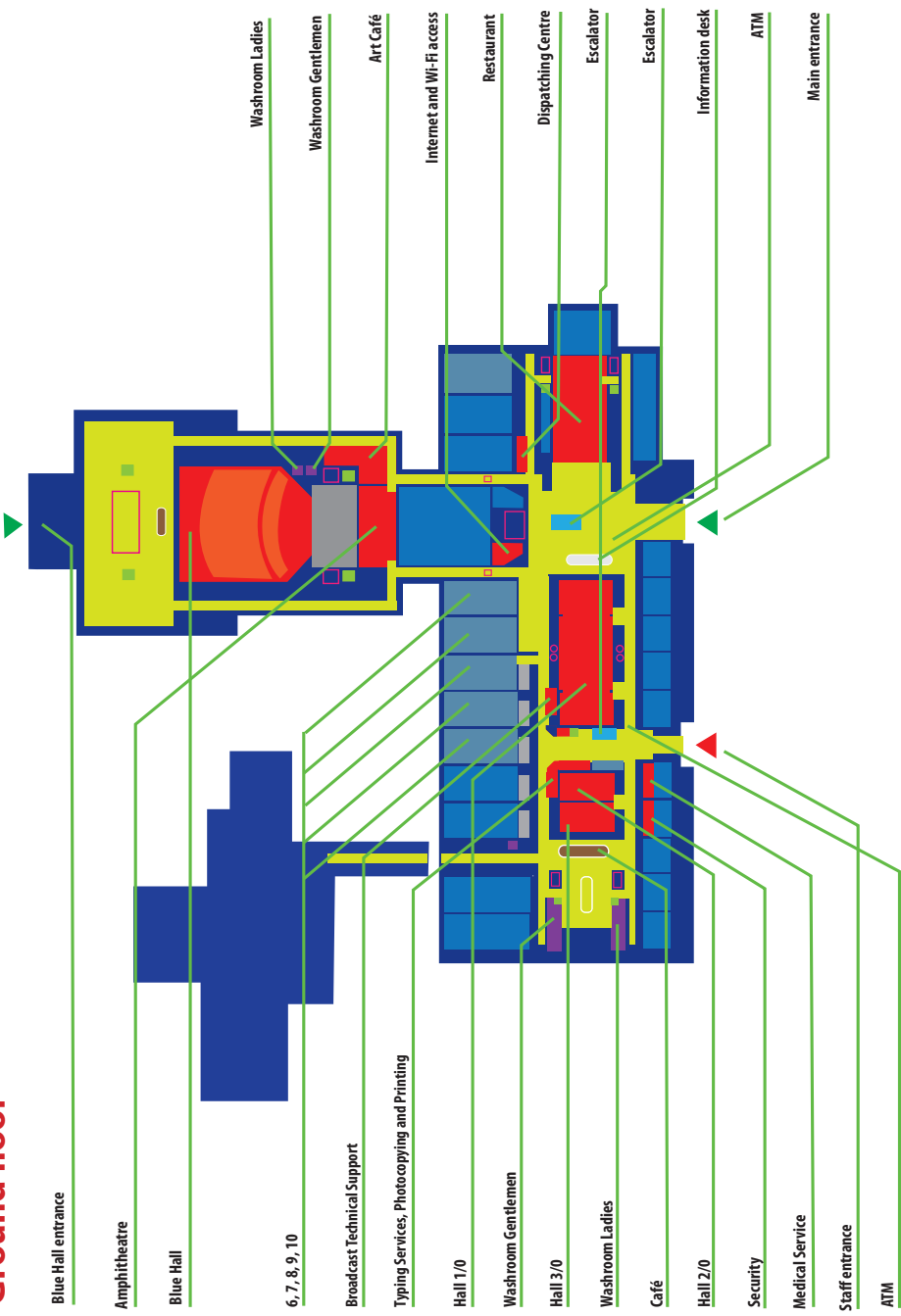

# First floor

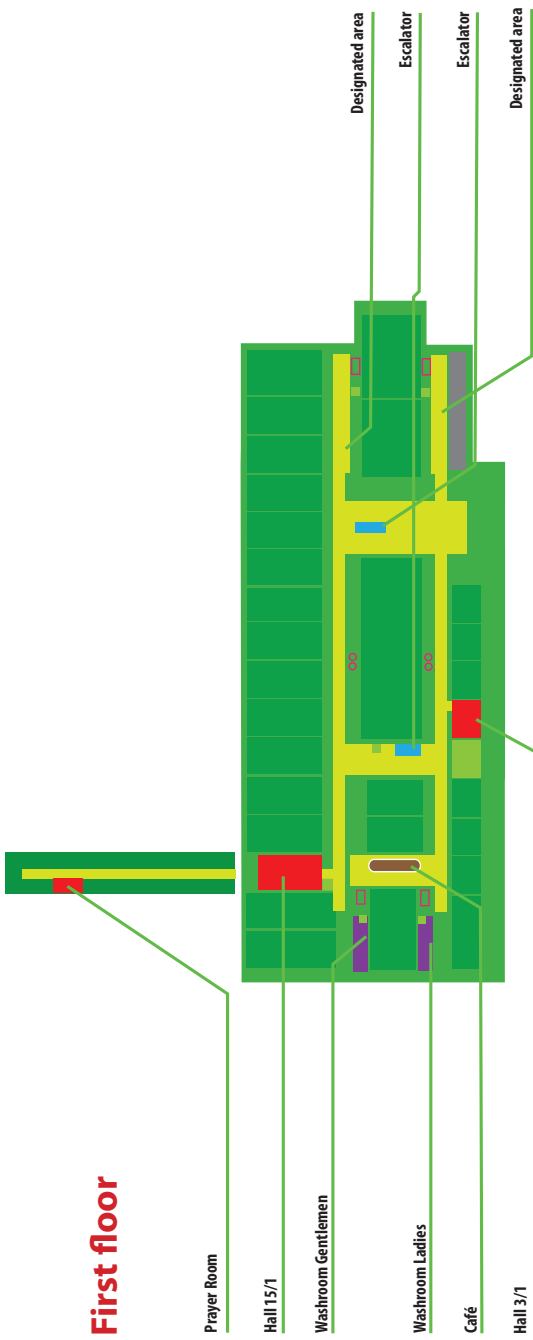

# Second floor

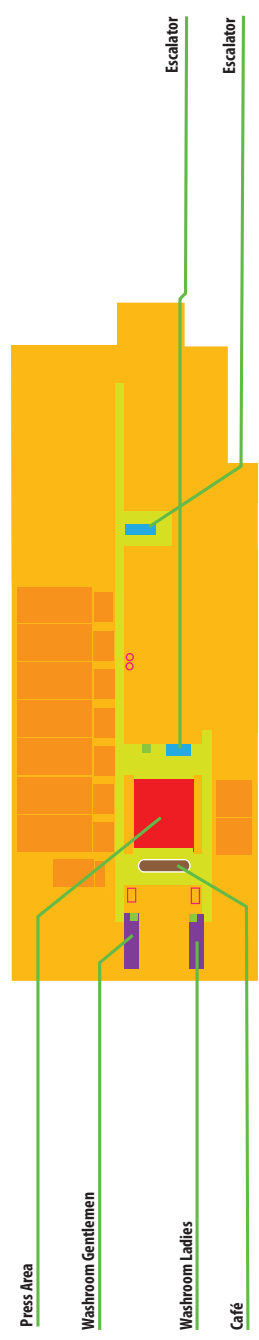

## LIST OF OFFICIAL ASSEMBLY HOTELS



**SQUARE NINE 5\***  
**dina.veljovic@squarenine.rs**  
Studentski trg 9, Belgrade  
Phone: +381 11 33 33 500  
+381 11 33 33 533  
Mob: +381 60 0 322 388

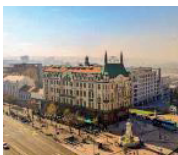

**MOSKVA 4\***  
**sales@hotelmoskva.rs**  
Terazije 20, 11 000 Beograd  
Tel: +381 11 36 42 000  
Fax: +381 11 26 88 389

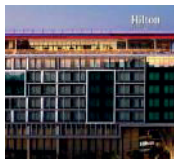

**HILTON Belgrade 4\***  
**marija.marinkovic@hilton.com**  
Kralja Milana 35, Belgrade  
+381-11-7555700  
FAX: +381-11-7555701



**PALACE 4\***  
Topličin Venac 23, Belgrade  
**office@palacehotel.rs**  
+381 11 218 5585  
+381 11 218 448

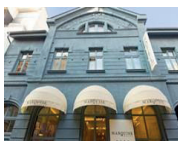

**Hotel MARQISE 4\***  
**info@marqisehotel.rs**  
Phone: +381 69 1400211



**SLAVIJA GARNI 3\***  
**sales@slavijahotel.com**  
Svetog Save 2, Belgrade  
Phone: +381 11 3084800

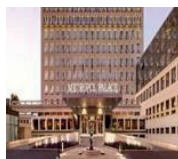

**METROPOL PALACE 5\***  
**kruna.pavlica@metropolpalace.com**  
Bulevar Kralja Aleksandra 69, Belgrade  
Phone: +381 11 3333100

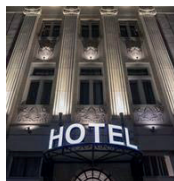

**SAINT TEN 5\***  
**reservations@saintten.com**  
Svetog Save 10, Belgrade  
info@saintten.com  
Phone: +381 11 411 66 33



**RADISSON COLLECTION 4\***  
**reservations.belgrade@radissoncollection.com**  
Bulevar Vojvode Mišića 15, Belgrade



**MERCURE BELGRADE EXCELSIOR 4\***  
**hb1e1-sl@accor.com**  
Kneza Miloša 5, Belgrade  
Tel: (+381)11/3231381

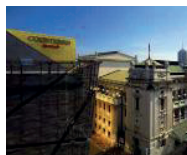

**MARRIOTT COURTYARD 4\***  
**danijela.korolija@marriott.com**  
Vase Čarapića 2-4, Belgrade  
+381 11 4003000

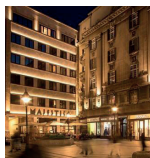

**MAJESTIC 4\***  
**office@majestic.rs**  
Obilićev venac 28, Belgrade  
Phone: +381 11 3285777



**PARK 3\***  
**tamara.obradovic@hotelparkbeograd.rs**  
Njegoševa 2/a, Belgrade  
+381 11 414 68 00



CROWN PLAZA 4\*  
[nemanja.mihajlovic@ihg.com](mailto:nemanja.mihajlovic@ihg.com)  
New Belgrade  
Vladimira Popovica 10,  
Tel. +381-11-2204004



HYATT REGENCY 5\*  
[belgrade.regency@hyatt.com](mailto:belgrade.regency@hyatt.com)  
Milentija Popovica 5, New  
Belgrade  
Tel: +381 11 301 1234



FALKENSTEINER 4\*  
[rezervacije.beograd@falkensteiner.com](mailto:rezervacije.beograd@falkensteiner.com)  
Bulevar Mihaila Pupina 10K  
New Belgrade  
+381 11 225 0000



IN Hotel 4\*  
[frontoffice@inhotel-belgrade.rs](mailto:frontoffice@inhotel-belgrade.rs)  
Bulevar Zorana Djindjica 58,  
New Belgrade  
+381 11 310 53 00



Hotel ADMIRAL ARENA 4\*  
[info@admiralhotelarena.rs](mailto:info@admiralhotelarena.rs)  
Phone: +381 11 4116611



HOLIDAY INN 4\*  
[rezervacije@hibelgrade.rs](mailto:rezervacije@hibelgrade.rs)  
Španskih Boraca 74, New  
Belgrade  
1 888 HOLIDAY



TULIP INN PUTNIK 3\*  
[ozuvic@tulipinnputnikbelgrade.com](mailto:ozuvic@tulipinnputnikbelgrade.com)  
Palmira Toljatija 9, New Belgrade  
+33 1 70 98 61 18  
+381 11 2259999

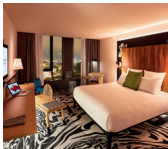

MAMA SHELTER BELGRADE  
[belgrade@mamashelter.com](mailto:belgrade@mamashelter.com)

Kneza Mihaila 54A,  
Beograd 11000, Serbia  
T +381 11 3333 020 / M  
+381 64 8500 340

## LIST OF EMBASSIES AND CONSULATES IN BELGRADE

No.	Country	Name of embassy	Tel. no.	Fax	Country code	E-mail
	ALBANIA	EMBASSY OF THE REPUBLIC OF ALBANIA	+3813066-642	+3812665-439	+355	<a href="mailto:embassy.belgrade@mfa.gov.al">embassy.belgrade@mfa.gov.al</a>
	ALGERIA	EMBASSY OF THE PEOPLE'S DEMOCRATIC REPUBLIC OF ALGERIA	+3813671-211; +3813671-213	+3812668-200	+234	<a href="mailto:ambalgerie-serbie@eunet.rs">ambalgerie-serbie@eunet.rs</a> <a href="http://www.ambalgerie.rs">www.ambalgerie.rs</a>
	ANGOLA	EMBASSY OF THE REPUBLIC OF ANGOLA	+3812666-457, +3813672-150	+3812660-729	+244	<a href="mailto:ambasada.angole@sbb.rs">ambasada.angole@sbb.rs</a> <a href="http://www.angola.embassy.org.rs">www.angola.embassy.org.rs</a>
	ARGENTINA	EMBASSY OF THE ARGENTINE REPUBLIC	+3812623-751; +3812623-569; +3812621-550	2622-630	+54	<a href="mailto:eserb@mtrecic.gov.ar">eserb@mtrecic.gov.ar</a>
	AUSTRALIA	EMBASSY OF THE COMMONWEALTH OF AUSTRALIA	+3813303-400	+3813303-409	+61	<a href="mailto:belgrade.embassy@dfat.gov.au">belgrade.embassy@dfat.gov.au</a>
	AUSTRIA	EMBASSY OF THE REPUBLIC OF AUSTRIA	+3813336-500	+3812635-606	+43	<a href="mailto:belgrad-ob@bmeia.gvat">belgrad-ob@bmeia.gvat</a>
	AZERBAIJAN	EMBASSY OF THE REPUBLIC OF AZERBAIJAN	+3813515-101, +3813515-102	+3813515-103	+994	<a href="mailto:belgrade@mission.mfa.gov.az">belgrade@mission.mfa.gov.az</a>
	BELARUS	EMBASSY OF THE REPUBLIC OF BELARUS	+3813616-938	+3813616-836	+375	<a href="mailto:serbia@mfa.gov.by">serbia@mfa.gov.by</a>
	BELGIUM	EMBASSY OF THE KINGDOM OF BELGIUM	+3813230-018; +3813247-587	+3813244-394	+32	<a href="mailto:belgrade@diplobel.fed.be">belgrade@diplobel.fed.be</a>
	BOSNIA AND HERZEGOVINA	EMBASSY OF BOSNIA AND HERZEGOVINA	+3813241-095, +3813241-170	+3813241-057	+387	<a href="mailto:bihambasada@sbb.rs">bihambasada@sbb.rs</a>



	BRAZIL	EMBASSY OF THE FEDERATIVE REPUBLIC OF BRAZIL	+3813239-781	+3813230-653	+55	<a href="mailto:brasemb.belgrado@itamaraty.gov.br">brasemb.belgrado@itamaraty.gov.br</a>
	BULGARIA	EMBASSY OF THE REPUBLIC OF BULGARIA	+3813613-980, +3813613-990, +3813610-644	+3813620-116	+359	<a href="mailto:embassy.belgrade@mfa.bg">embassy.belgrade@mfa.bg</a>
	CANADA	EMBASSY OF CANADA	+3813063-000	+3813063-042, +3813063-035	+1	<a href="mailto:bgrad@international.lgc.ca">bgrad@international.lgc.ca</a>
	CHINA	EMBASSY OF THE PEOPLE'S REPUBLIC OF CHINA	+3812067-934	+3813695-057, +3813066-001	+86	<a href="http://rs.chineseembassy.org">http://rs.chineseembassy.org</a>
	CROATIA	EMBASSY OF THE REPUBLIC OF CROATIA	+3813679-150; +3813679-151	+3813610-032	+385	<a href="mailto:croebg@mvep.hr">croebg@mvep.hr</a>
	CUBA	EMBASSY OF THE REPUBLIC OF CUBA	+3813692-441, +3813692-689	+38133-4323	+53	<a href="mailto:recepcion@ambasadakube.org.rs">recepcion@ambasadakube.org.rs</a>
	CYPRUS	EMBASSY OF THE REPUBLIC OF CYPRUS	+3813620-002	+3813621-122	+357	<a href="mailto:cypriusembassybelgrade@sbb.rs">cypriusembassybelgrade@sbb.rs</a>
	CZECH REPUBLIC	EMBASSY OF THE CZECH REPUBLIC	+3813336-200	+3813236-448	+420	<a href="mailto:belgrade@embassy.mzv.cz">belgrade@embassy.mzv.cz</a>
	DEMOCRATIC REPUBLIC OF THE CONGO	EMBASSY OF THE DEMOCRATIC REPUBLIC OF THE CONGO	+3813446-431		+243	<a href="mailto:rd.congobelgrade@gmail.com">rd.congobelgrade@gmail.com</a>
	DENMARK	EMBASSY OF THE KINGDOM OF DENMARK	+3813679-500, +3813679-503	+3814060-500	+45	<a href="mailto:begamb@um.dk">begamb@um.dk</a>
	EGYPT	EMBASSY OF THE ARAB REPUBLIC OF EGYPT	+3812650-585, +3812652-036	+3812651-225	+20	<a href="mailto:egemb@sbb.rs">egemb@sbb.rs</a>
	EUROPEAN UNION	DELEGATION OF THE EUROPEAN UNION	+3813083-200	+3813083-201		<a href="mailto:delegation-serbia@eeas.europa.eu">delegation-serbia@eeas.europa.eu</a>
	FINLAND	EMBASSY OF THE REPUBLIC OF FINLAND	+3813065-400	+3813065-375	+358	<a href="mailto:sanomatieo@formin.fi">sanomatieo@formin.fi</a>
	FRANCE	EMBASSY OF THE FRENCH REPUBLIC	+3813023-500	+3813023-510	+33	<a href="mailto:service-presse.belgrade-amba@diplomatie.gouv.fr">service-presse.belgrade-amba@diplomatie.gouv.fr</a>
	GERMANY	EMBASSY OF THE FEDERAL REPUBLIC OF GERMANY	+3813064-300	+3813064-303	+49	<a href="mailto:info@belg.diplode">info@belg.diplode</a>
	GREECE	EMBASSY OF THE HELLENIC REPUBLIC	+3813226-523	+3813344-746	+30	<a href="mailto:gremb.bel@mfa.gr">gremb.bel@mfa.gr</a>
	GUINEA	EMBASSY OF THE REPUBLIC OF GUINEA	+3813444-840; +3812451-391	+3813444-870	+224	<a href="mailto:ambaguineebelgrade@eunet.rs">ambaguineebelgrade@eunet.rs</a>
	HUNGARY	EMBASSY OF HUNGARY	+3812440-472, +3812447-039,	+3813441-876	+36	<a href="mailto:mission.blg@mfa.gov.hu">mission.blg@mfa.gov.hu</a>
	INDIA	EMBASSY OF THE REPUBLIC OF INDIA	+3812667-990, +3812666-520	+3813674-209	+91	<a href="mailto:indemb@eunet.rs">indemb@eunet.rs</a>

	INDONESIA	EMBASSY OF THE REPUBLIC OF INDONESIA	+3813635-666	+3813672-984	+62	<a href="mailto:kbri.beograd@eunet.rs">kbri.beograd@eunet.rs</a>
	IRAN (ISLAMIC REPUBLIC OF)	EMBASSY OF THE ISLAMIC REPUBLIC OF IRAN	+3813674-360	+3813674-363	+98	<a href="mailto:iranemb.beg@mfa.gov.ir">iranemb.beg@mfa.gov.ir</a>
	IRAQ	EMBASSY OF THE REPUBLIC OF IRAQ	+3812647-027	+3812668-068	+964	<a href="mailto:iraqembassybg@yahoo.com">iraqembassybg@yahoo.com</a>
	ISRAEL	EMBASSY OF THE STATE OF ISRAEL	+3813643-500	+3813643-555	+972	<a href="mailto:info@belgrade.mfa.gov.il">info@belgrade.mfa.gov.il</a>
	ITALY	EMBASSY OF THE ITALIAN REPUBLIC	+3813066-100	+3813249-413	+39	<a href="mailto:segreteria.belgrado@esteri.it">segreteria.belgrado@esteri.it</a>
	JAPAN	EMBASSY OF JAPAN	+3813012-800	+3817118-258	+81	<a href="mailto:protocol@s1.mofa.go.jp">protocol@s1.mofa.go.jp</a>
	KAZAKHSTAN	OFFICE OF THE EMBASSY OF THE REPUBLIC OF KAZAKHSTAN IN BUDAPEST	+381362-9194		+7	<a href="mailto:kazserbia@mail.ru">kazserbia@mail.ru</a>
	KUWAIT	EMBASSY OF THE STATE OF KUWAIT	+3812661-417	+3812668-462	+965	<a href="mailto:kuwaitembassybg.ome@gmail.com">kuwaitembassybg.ome@gmail.com</a>
	LEBANON	EMBASSY OF THE REPUBLIC OF LEBANON	+3813675-153; +3813675-154	+3813675-156	+961	<a href="mailto:ambaleb@sbb.rs">ambaleb@sbb.rs</a>
	LIBYA	EMBASSY OF LIBYA	+3812663-445; +3812668-253	+3813670-805	+218	<a href="mailto:lbyaamb@open.telekom.rs">lbyaamb@open.telekom.rs</a>
	MALAYSIA	EMBASSY OF MALAYSIA	+3812662-736, +3812662-746	+3813679-080	+60	<a href="mailto:mwbelgrade@kln.gov.my">mwbelgrade@kln.gov.my</a>
	MEXICO	EMBASSY OF THE UNITED MEXICAN STATES	+3813674-171		+52	<a href="mailto:embs Serbia@sre.gob.mx">embs Serbia@sre.gob.mx</a>
	MONTENEGRO	EMBASSY OF MONTENEGRO	+3812662-300	+3817702-300	+382	<a href="mailto:emb.belgrade@mfa.gov.me">emb.belgrade@mfa.gov.me</a>
	MOROCCO	EMBASSY OF THE KINGDOM OF MOROCCO	+3813690-288; +3813691-866	+3813690-499	+212	<a href="mailto:midi@ambasada-maroka.org.rs">midi@ambasada-maroka.org.rs</a>
	MYANMAR	EMBASSY OF THE REPUBLIC OF THE UNION OF MYANMAR	+3813617-165; +3813619-114	+3813614-968	+95	<a href="mailto:myanbel@sezampro.rs">myanbel@sezampro.rs</a>
	NETHERLANDS	EMBASSY OF THE KINGDOM OF THE NETHERLANDS	+3812023-900	+3812023-999	+31	<a href="mailto:bel@minbuza.nl">bel@minbuza.nl</a>
	NORTH MACEDONIA	EMBASSY OF THE REPUBLIC OF NORTH MACEDONIA	+3813284-924	+3813285-076	+389	<a href="mailto:belgrade@mfa.gov.mk">belgrade@mfa.gov.mk</a>
	NORWAY	EMBASSY OF THE KINGDOM OF NORWAY	+3813208-000	+3813208-001	+47	<a href="mailto:emb.belgrade@mfa.no">emb.belgrade@mfa.no</a>
	PAKISTAN	EMBASSY OF THE ISLAMIC REPUBLIC OF PAKISTAN	+3812661-676	+3812661-667	+92	<a href="mailto:parepbelgrade@mofa.gov.pk">parepbelgrade@mofa.gov.pk</a>
	PALESTINE	EMBASSY OF PALESTINE	+3813671-407	+3813671-336	+970	<a href="mailto:office@embassyofpalestine.rs">office@embassyofpalestine.rs</a>

	POLAND	EMBASSY OF THE REPUBLIC OF POLAND	+3812065-301, +3812065-322	+3813617-576	+48	<a href="mailto:belgrad.amb.sekretariat@msz.gov.pl">belgrad.amb.sekretariat@msz.gov.pl</a>
	PORTUGAL	EMBASSY OF THE PORTUGUESE REPUBLIC	+3812662-894, +3812662-897	+3812647-800	+351	<a href="mailto:portambseverat.net">portambseverat.net</a>
	QATAR	EMBASSY OF THE STATE OF QATAR	+381635-6666	+381635-6661	+974	<a href="mailto:sec.belgrade@mofa.gov.qa">sec.belgrade@mofa.gov.qa</a>
	REPUBLIC OF KOREA	EMBASSY OF THE REPUBLIC OF KOREA	+3813674-225	+3813674-229	+82	<a href="mailto:koreaemb.rs@mofa.go.kr">koreaemb.rs@mofa.go.kr</a>
	ROMANIA	EMBASSY OF ROMANIA	+3813675-772/4	+3813675-771	+40	<a href="mailto:belgrad@mae.ro">belgrad@mae.ro</a>
	RUSSIAN FEDERATION	EMBASSY OF THE RUSSIAN FEDERATION	+3813611-323, +3813611-090,	3611-900	+7	<a href="mailto:info@ambarusk.rs">info@ambarusk.rs</a>
	SLOVAKIA	EMBASSY OF THE SLOVAK REPUBLIC	+3812223-801	+3812223-820	+386	<a href="mailto:emb.beograd@mzv.sk">emb.beograd@mzv.sk</a>
	SLOVENIA	EMBASSY OF THE REPUBLIC OF SLOVENIA	+3813038-476	+3813288-657	+386	<a href="mailto:vbg@gov.si">vbg@gov.si</a>
	SPAIN	EMBASSY OF THE KINGDOM OF SPAIN	+3813440-231	+3813444-203	+34	<a href="mailto:emb.belgrado@maec.es">emb.belgrado@maec.es</a>
	SWEDEN	EMBASSY OF THE KINGDOM OF SWEDEN	+3812069-200	+3812069-250	+46	<a href="mailto:ambassaden.belgrad@gov.se">ambassaden.belgrad@gov.se</a>
	SWITZERLAND	EMBASSY OF THE SWISS CONFEDERATION	+3813065-820, +3813065-825	+3812657-253, +3813065-815	+41	<a href="mailto:bel.vertretung@eda.admin.ch">bel.vertretung@eda.admin.ch</a>
	SYRIAN ARAB REPUBLIC	EMBASSY OF THE SYRIAN ARAB REPUBLIC	+3812666-124; +3812666-125,	+3812660-221	+963	<a href="mailto:ambasada.sirije@open.telekom.rs">ambasada.sirije@open.telekom.rs</a>
	TUNISIA	EMBASSY OF THE TUNISIAN REPUBLIC	+3813690-194	+3812651-848	+216	<a href="mailto:at.belgrade@sbb.rs">at.belgrade@sbb.rs</a>
	TURKEY	EMBASSY OF THE REPUBLIC OF TURKEY	+3813332-400	+3813332-433	+90	<a href="mailto:embassy.belgrade@mfa.gov.tr">embassy.belgrade@mfa.gov.tr</a>
	UKRAINE	EMBASSY OF UKRAINE	+3813672-411; +3813672-412	+3813672-413	+380	<a href="mailto:emb_rs@mfa.gov.ua">emb_rs@mfa.gov.ua</a>
	UNITED ARAB EMIRATES	EMBASSY OF THE UNITED ARAB EMIRATES	+3814020-500	+3814020-501	+971	<a href="mailto:BelgradeEMB@mofaic.gov.ae">BelgradeEMB@mofaic.gov.ae</a>
	UNITED KINGDOM	EMBASSY OF THE UNITED KINGDOM OF GREAT BRITAIN AND NORTHERN IRELAND	+3813060-900	+3813061-070	+44	<a href="mailto:belgrade.man@fco.gov.uk">belgrade.man@fco.gov.uk</a>
	VENEZUELA (BOLIVARIAN REPUBLIC OF)	EMBASSY OF THE BOLIVARIAN REPUBLIC OF VENEZUELA	+3812668-384	+3812669-233	+58	<a href="mailto:embve.besrb@mppre.gob.ve">embve.besrb@mppre.gob.ve</a>